

# Clark County Universal Green Design Idea Book

*Information and ideas to make your home last a lifetime*



CLARK COUNTY COMMISSION ON AGING

**Universal Green Design** is a long-term approach to building and remodeling that combines environmentally sustainable elements of green building with the flexibility of universal design. Universal design uses simple, proven ideas to make any home more comfortable for a wide range of people:



- ✓ Families with young children
- ✓ People who want to stay in their homes as they grow older
- ✓ People who are taller or shorter than average
- ✓ People who use wheelchairs or walkers

Appropriate home design helps people enjoy the full use of their home, host guests with varying abilities, and maintain their independence. Well-designed homes are one component of a strategy to enable residents to have the opportunity to "age-in-place".

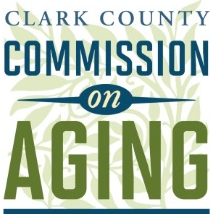

Clark County, Wash., like everywhere in the country, is anticipating a huge surge in the number of residents 60 or better. Today, one in six residents is 60 or older, and the number will increase to one in four by 2030.

With a silver tidal wave coming our way, the Board of Clark County Commissioners appointed a 9-member Commission on Aging in June 2012. The commission is charged with implementing the 91 strategies in the [Aging Readiness Plan](#) to improve the community's capacity to support its growing older population and ultimately benefit all ages.

Universal Green Design is one of those 91 strategies. Affordable and adaptable housing is essential for people to be able to age-in-place. We hope this idea book provides information and inspiration for those looking to remodel their existing homes or for those planning on building a new home with the forethought to insure they can live in it as long as they choose.

**May 2014**

---

## Table of Contents

Introduction .....	4
What is Universal Design?.....	5
Why Build Green? .....	5
How to get started.....	6
Exterior .....	8
Entrance and Doorways .....	11
Pathways – Getting Around .....	14
Kitchen.....	16
Bathroom .....	18
Bedroom.....	20
Closets and Storage .....	21
Laundry.....	22
Covered Switches, Outlets and Controls .....	23
Garage and Carports.....	25
Windows.....	25
Stairs and Elevators .....	26
Other things to consider.....	27

## Introduction

Let's face it, buying a home is an expensive proposition. Most people don't think far into the future when buying a home or how it could save them money over time. Home buyers want a "deal" and might not think about how well a home could work for them. Imagine buying a home that's a great deal, but has four levels. The style is great, but can get tiring - literally. Carting groceries and laundry up and down stairs can get old. Most home buyers don't think about a floor plan that's easy to live with over many years.

Many people find floor plans and lifestyles that work for them. But sometimes an idea comes along that's so good, we wonder why we didn't think of it earlier. Universal Green Design (UGD) is such an idea. Universal Green Design is a long-term approach to residential building and remodeling that combines environmentally sustainable building elements with the comfort, safety and flexibility of universal design.



Photo courtesy of J. Wilson

The goal is simple: make products and places adaptable to people of all ages, shapes, sizes and abilities. UGD includes functional elements that accommodate all generations over time. It offers specific methods and materials so that your home can remain your home, even if you have significant health or lifestyle changes. Many people think aging-in-place and universal design have too many restrictions to be attractive to multi-generations. But if designed well and done right, a UGD home can be a family treasure.

### *Imagine...*

- A home your friends and family can visit comfortably
- A home that will be cost-efficient because it is energy-efficient
- A home that will meet your changing needs

---

## What is Universal Design?

Universal Design is a new approach to home design. By focusing on how the home is designed for ease of use, the final design adapts easier to changing needs. For example, a step-free entrance, open floor plan, wide doorways and generous pathways throughout a home make getting around trouble-free, whether on your feet or in a wheelchair. Installing lever door handles and rocker light switches makes every day actions much easier for everyone. With Universal Design, the whole family can experience home life to the fullest.

## Why Build Green?

Beyond incorporating the principles of Universal Design, building green will ease your life in other ways — primarily by reducing your utility and maintenance bills. The goal is to make your home more affordable, durable and comfortable while enhancing its value.



Photo courtesy of C. Evoniuk

## How to get started

As with everything, there is no “one-size fits all” approach. This guide will walk you through various activity areas of your home. As we discuss each area, we’ve highlighted the functional elements we consider *essential* and others *worth considering*. Be sure to read through everything once because elements build upon one another. The more elements you incorporate into your home, the more years you likely will enjoy it.

## Where do you want to live?

We’ve all heard the saying, “Location, location, location.” The word can mean many different things, but for Universal Green Design, it’s all about livability. So before looking at homes for sale or house plans, you need to think about where and how you want to live.

### Lot location

- Locate near services. Can you get around without a car?
- Access to outdoor activities. When you leave home, can you push a stroller to the park, place the garbage and recycling bins at the curb, visit the mailbox or enjoy your yard?
- Natural topography. Beware of hilly and mountainous areas. Hilly terrain may make it difficult to get around or reduce the amount of natural sunlight to the home.
- Location of the sun. Does the lot orientation take advantage of passive solar heating? For example, if the home sits on an east-west axis, you will maximize solar heat gain in the winter and minimize solar heat gain in the summer.
- How flat is the lot? Can you build a home with the master bedroom and all activity areas on the main floor? Clark County has a high water table in many areas, so watch out for standing water.

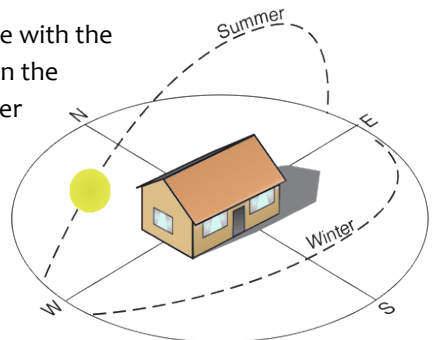

---

## Choosing a house floor plan

Spending time on home design early can save on expensive remodels later. Here are a few ideas to consider:

- How energy-efficient is the home?
  - **Home Energy Rating System (HERS)** is a national rating system developed by the U.S. Department of Energy. The score reflects energy efficiency based on the home's structure as well as heating, cooling and hot water systems. The lower the number, the better.
  - A **HERS** index of 65 means that the home is 35 percent more energy efficient than a home built to today's standards.
- How much square footage do you really need? A smaller home is easier to maintain and uses less energy.
- Open layout or "great room concept?" An open layout makes the space feel larger and is easy to get around in.
- Main floor living. Over time, going up and down stairs may become a challenge. Look for a home with the kitchen, a full bath, laundry area and at least one room that can be used as a bedroom on the main floor. Better yet, look for a single-story home.
- Maximize the sun's warmth to lower energy bills.
  - Are the kitchen and other activity areas near the south side of the home? Frequently rooms on the southern side will have sunrays in the winter and relief from the heat of the sun in the summer.
  - Are the garage, laundry room, closet and other areas used less frequently situated on the north part of the house? They will be buffers against chilly winter winds.
- Take a look at the ceiling heights. Different ceiling heights add interest and result in small spaces that feel spacious.
- Large windows brighten a room and draw the eye out onto the landscape. Nothing feels bigger than the great outdoors. Any window above eye level will cause the room to feel extra spacious and bring in natural sunlight.

Once you have an ideal floor plan, it's time to look at the details. We'll start with first impressions and walk you through accessing your home.

## Exterior

A well-known landscape concept describes the exterior of a home as a series of “garden rooms.” By creating separate garden rooms for relaxing, entertaining, pathways and utility areas, you give each part of your home’s exterior a different feel and maximize its functionality.

### Essentials

- ❑ One primary walkway from home to curb. The walkway should be at least 48 inches wide. This allows visitors to walk side-by-side or accommodates an electric scooter.
- ❑ The surface of the primary walkway needs to be safe, firm, stable and slip-resistant.
- ❑ Clear, easy access to outdoor destinations such as the mailbox, garbage and recycling bins, barbeque and newspaper.
- ❑ House numbers placed where they can be seen from the street. Choose an easy to read number style that is at least four inches high, illuminated at night and a contrasting color to the mounting area.



### Worth Considering

- ❑ Low maintenance exterior materials and trim. Many products require little or no paint, are fire retardant and prevent moss growth.
- ❑ Low maintenance landscaping. Use native trees, shrubs and plants that conserve water while minimizing upkeep. For more information, go to the WSU Clark County Extension at [http://clark.wsu.edu/volunteer/mg/gm\\_tips/Xeriscaping.html](http://clark.wsu.edu/volunteer/mg/gm_tips/Xeriscaping.html).



- Install raised garden planters, tables and beds at convenient heights. A garden table is an elevated bed allowing easy access from a standing position. A raised bed can be used as a sitting area if it is 24 inches high.

The width of a raised garden varies depending on location and use.



Photo courtesy of C. Anderson

The goal is a planting area no wider than an arm's reach

from the outside edge of the bed.

- Walkways and driveways function similar to a ramp. A UGD walkway is constructed with little or no slope and a flat resting area or “landing” at each end.

The ideal slope is 1:15 or less, so railings are not required. That means you need 15 feet horizontal distance to go up one foot vertically. As the primary access, the walkway and ramps should be a minimum of 48 inches wide, but 60 inches is preferred.

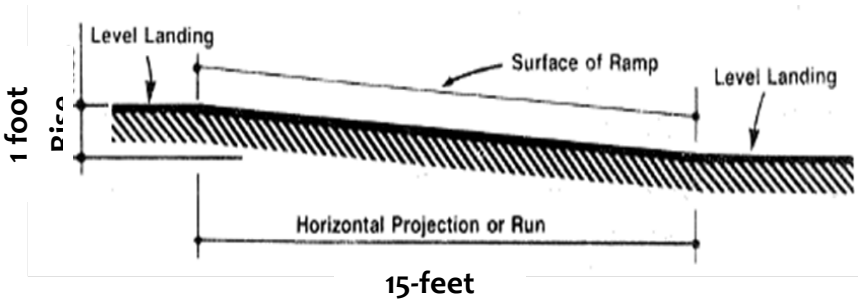

- ❑ Outdoor seating such as a bench, patio chair, low retaining wall or planter.
- ❑ Outdoor railings or other grab points along long pathways for balance and resting areas.
- ❑ Decks and patios built at the same level as the house for a step-free entrance to the home.
- ❑ If the perimeter of the deck or patio is elevated, consider installing a railing, bench, planter, curb or 2-inch stop bar to define the edge.
- ❑ For an elevated deck or patio, consider a ramp instead of stairs.
- ❑ Check on how the deck is constructed. Deck boards are ideally spaced no more than a ½-inch apart. Wider spacing is difficult for high heels and wheeled devices. Un-spaced boards catch moisture and promote seasonal slipping, green slime and dry rot. Choose a slip resistant material instead of wood, and pay careful attention to allowable span limitations of this material.



## Entrance and Doorways

Look familiar? So many times getting in and out of your home can be an adventure.

### Essentials

- At least one entry into the home that is step-free and connects to the primary walkway.
- A step-free threshold is typically no higher than a half inch. Most door manufactures describe this type of threshold as an ADA threshold.
- All doorways need to be a minimum of 36 inches wide so the space between the door frames is 32 inches minimum clear space. If you have the room, a 42-inch door for the entry works better than a 36-inch door.
- Lever-style, 4-inch-long door handles are particularly helpful when your hands are full or you cannot grasp a knob.



Photo courtesy of C. Frayer

- Clear floor space on either side of the door for a person using a mobility aid to reach the door lever, open the door, and be outside of the door swing.

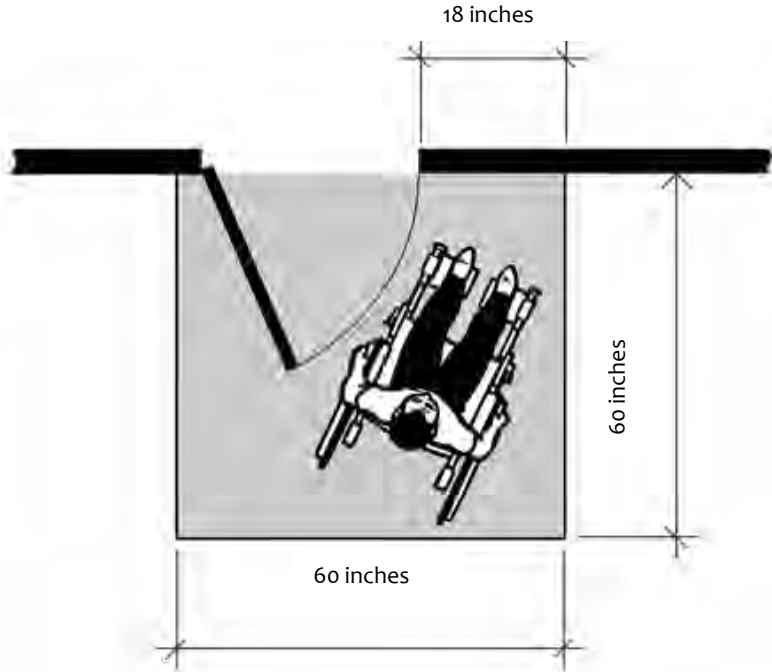
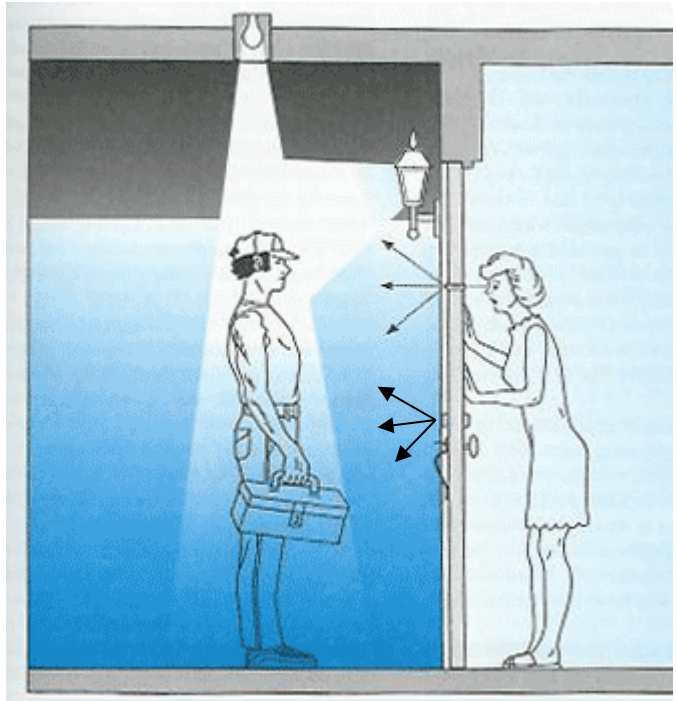

Figure courtesy of HUD Fair Housing Act Design Manual

The actual clear floor space needed depends on the direction of approach to and from the door. The space should include a 36-inch pathway on both sides of the door and at minimum, 18 inches beside the door closest to the door lever. Whenever possible, provide a level, clear 60-inch area for maneuvering, especially on an outside landing.

## Worth Considering

- Provide a porch, awning or shelter from the weather.
- Place a bench or shelf nearby to hold items while opening the door.
- Install a Westminster chime doorbell. This chime plays eight-notes giving the homeowner more information than a traditional two-note doorbell. It has frequencies from low to high, and is great for folks with hearing loss.
- Add a lighted doorbell.
- Install a wide-angle peep hole in a solid entry door at the level of an average adult standing or sitting (42-48 inches above the floor), and/ or install a full-length sidelight beside the door.
- Replace a traditional deadbolt lock on the door with a keyless lock and remote control or keypad. The deadbolt lock is battery operated, and has a backlit keypad outside and thumb latch inside. Great for kids or a home helper as it eliminates the need to have your doors re-keyed. Rather, just change the code. Batteries should be replaced when you change smoke detector batteries.
- Light the area around your doors. Use a motion detector light or a photocell light sensor for security.
- Pre-wire for an intercom system.
- Pre-wire for a push-button power door.



## Pathways – Getting Around

Once inside the home, how do you maneuver from room to room? What about getting around within each room? Realistically, it's much easier to modify a new home plan than it is to change the home's "bones" during a remodel. You'll find many ways to adapt your home for easy interior circulation.

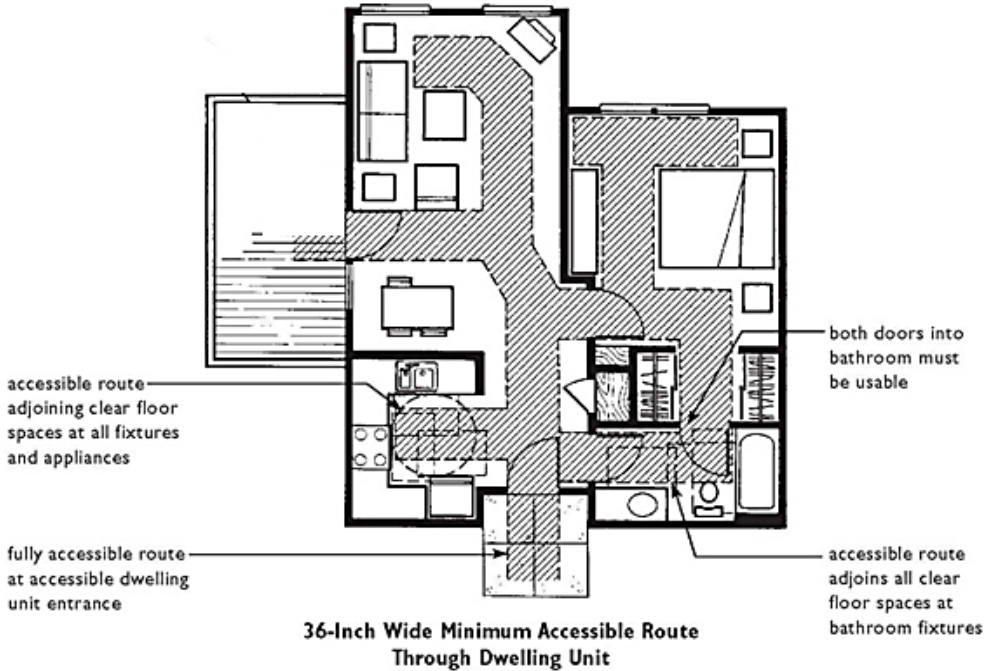

Figure courtesy of HUD Fair Housing ACT Design Manual

---

## Essentials

- Look at your hallways. Are they a minimum of 36 inches wide? You will appreciate the extra room; it helps avoid wall scrapes and door nicks.
- Is there a primary pathway or accessible route between rooms and to main activity areas within a room? The primary pathway should be a minimum of 36 inches wide. We will discuss each activity area in detail later.
- How wide are your doors? Just like the primary entrance, ideally each doorway – especially your bedroom and one full UGD bathroom – should have a minimum of 32 inches of clear space.

## Worth Considering

- New homes and remodels should plan for 36-inch doors, either pocket doors or doors with lever-style handles. This gives you space to navigate room to room.
- Single level throughout the interior – no sunken floors, steps or split levels.
- Pocket or sliding door instead of a swing door to free up floor space.
- Floor finishes that minimize glare and are slip-resistant.

## Kitchen

The kitchen is where the mind, body and spirit are nourished. As part of an open floor plan, it is the heart of the home where family and friends gather. This area is essential to daily living. It also is the most difficult room to describe how UGD can make a difference.

To get the conversation started, we've included two fully accessible Universal Design kitchen layouts. They were designed for The Home Store by the late Ron Mace, FAIA, when he was the director of the Center for Universal Design at North Carolina State University. Most home stores offer UGD appliances, cabinets, hardware and a kitchen design specialists to help you.

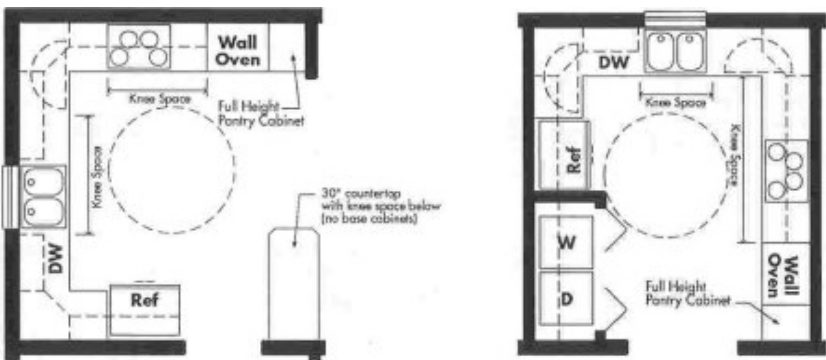

### Essential

- Counter space next to appliances on which to set dishes or cookware.
- A single lever faucet.
- Good task lighting over work areas.
- Easy access to kitchen storage: pull-out shelves, lazy Susan in the corner, pull-out boards.
- Loop-style or D-shaped cabinet hardware for drawers and doors.
- Plenty of open floor space to maneuver, especially when the dishwasher, oven or refrigerator doors are open. A good rule of thumb: a minimum of 60 inches between cabinet faces and those directly opposite.
- Rounded corners, no sharp edges on counters.
- Appliance controls that are easy to read, easy to reach and tell you if something is hot.



## Worth Considering

- Easy guide drawers and cabinet doors that close automatically.
- Touchless faucet with single lever handle.
- Some electrical switches and outlets placed near the front edge of the lower cabinets for easier access.
- A side-by-side style refrigerator gives more access when sitting. The doors are easier to open/close and protrude less.
- Counters and other work surfaces at two different heights – standing and sitting.
- Raised dishwasher with cabinet or drawer underneath to reduce bending.
- Install a wall oven to allow for sitting at the cook top. Make sure extra counter space is nearby to help transition items from the oven.



Photo courtesy of GE Kitchen Design



Photo courtesy of C. Frayer



Photo courtesy of The Home Store

- A cooktop with removable cabinets to allow sitting at the cooktop.
- The sink should be installed with plumbing toward the back of the cabinet. At some point in the future, you might want to sit while using the sink. The cabinet doors and shelf may need to be removed, and in this way, the plumbing would not need to be changed. The sink cabinet should be 42 inches wide.

## Bathroom

A Universal Green Design home is friendly to you and your guests. A UGD bathroom is an area vital to staying in your home throughout your lifetime.

### Essential

- Ample floor space for maneuvering between fixtures and task areas. A 60- by 60-inch area is preferred; at a minimum, 30 inches by 40 inches.
- Shower should be a minimum of 36 inches by 60 inches.
- An adjustable-height, handheld showerhead that's easy to reach and operate. Several models also incorporate a grab bar.
- Lighting and heat lamp near the shower.
- Rounded corners, no sharp edges on counters.
- Towel bars and hooks should be mounted 35-48 inches above the floor.
- Toilet seat height 17-19 inches high with flush control handle closest to you. If possible, the center line of the toilet should be located 18 inches from a wall or obstruction. Use an elongated bowl style. Most home stores carry this item.

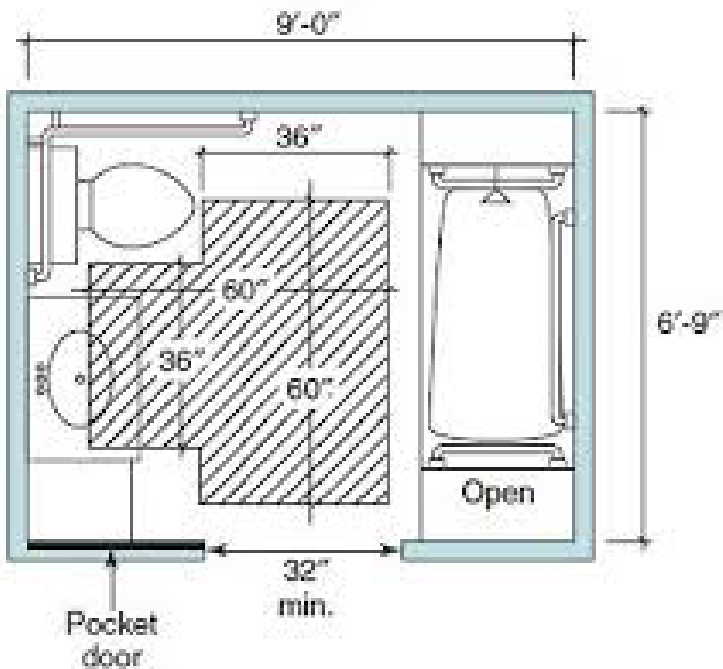

## Worth Considering

- Install wood blocking in the wall around the toilet and shower for future grab bar installation. The blocking needs to be 1 ½-inch thick and placed 30 inches above the floor.
- An electrical outlet close to the toilet.
- A walk-in (curbless) shower. The shower entry needs to have 32 inches of clear space. The floor tile needs to be slip resistant.
- A retractable shower bench or seat installed at 17 inches above the floor.
- Mirrors placed for both standing and sitting.
- Good-quality, non-glare lighting.
- Pocket doors instead of swinging doors.
- Telephone jack in the bathroom to call for help.
- Grab bars 1 ¼ to 2 inches in diameter. The color of the grab bars should contrast with the wall color.
- A pedestal style sink allows for more floor clearance.
- Install a sink and cabinet so the plumbing is toward the back of the cabinet. The cabinet should be 42 inches wide. Over time, you may have the cabinets modified with slide back doors and no toe kick to allow opening the doors, sliding them back alongside the cabinet and being able to sit at the sink.

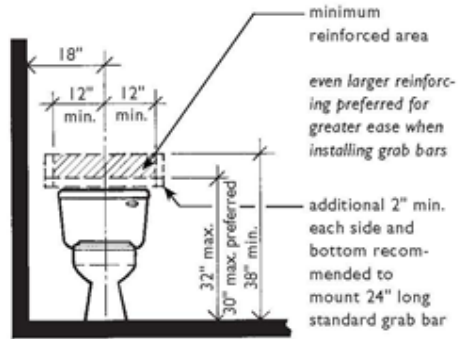

**Minimum Reinforcing Behind Toilets Located Beside a Wall**

Figure courtesy of HUD Fair Housing ACT Design Manual



Photo courtesy of Gilman Design Build

## Bedroom

A UGD bedroom focuses more on easy access to and from the bed rather than the furniture. It's important to make sure you have a primary pathway to one side of the bed, bath and closet.

### *Essential*

- Ample maneuvering space – at least 36 inches on both sides of the bed and ideally 60 inches on one side of the bed.
- Light switches reachable from the bedside and door.
- Telephone jack near the bed.

### *Worth Considering*

- Extra electrical outlets near the bed for rechargeable items or medical equipment.
- A safety exit to outdoors.



Photo courtesy of Home Depot Decor

## Closets and Storage

Access to closets and storage areas relies on the primary pathway to the closet and type of doors used. Here are a few examples that will make life easier:

### Essential

- Closet rods reachable from a seated or standing position. Adjustable height rods are ideal.



### Worth Considering

- Well-lit with a switch located outside the storage area or by motion sensor.
- The closet opening needs 32 inches of clear space.

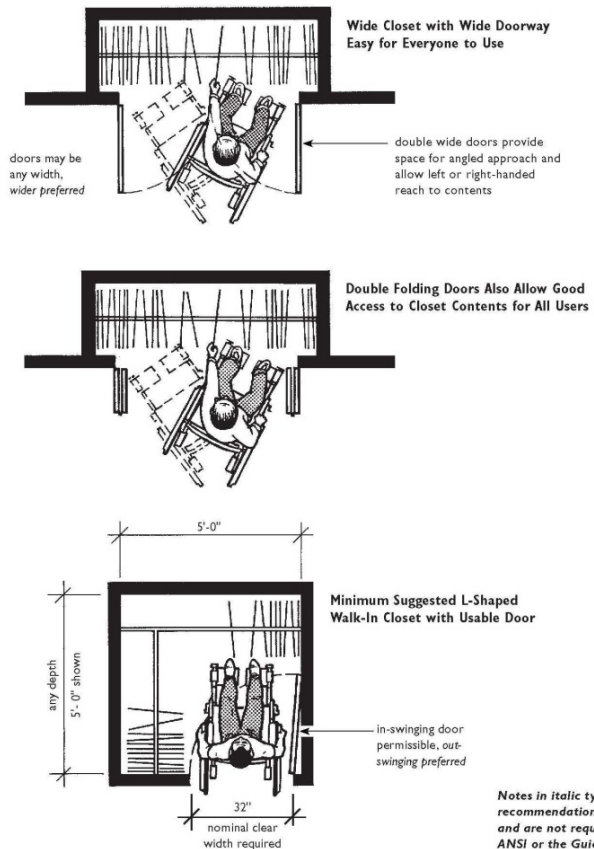

Figure courtesy of HUD Fair Housing ACT Design Manual

## Laundry

This area should be on the main floor. The key UGD element is providing clear maneuvering space in front of the washer and dryer, especially while the doors are open. Sometimes the machines share activity space in other rooms. Make sure the doors can be opened without hampering access to the machines.

### *Essential*

- Good task lighting in the work area.
- Appliance controls that are easy to reach and operate.

### *Worth Considering*

- Front-loading washer and dryer, placed on raised platforms to reduce bending and kneeling. For most people, a side swinging door is best. The raised platform can be used for storage.
- Lowered work surface that allows seating underneath.
- Main water shut-off valve within reach.



Photo courtesy of Home Depot Decor

## Covered Switches, Outlets and Controls

This area of UGD is easier to achieve with new construction or a large remodel.

### Essential

- Programmable thermostat that is easy to read and placed about 48 inches above the floor.
- Large rocker-style switches that can be operated with a closed fist or elbow and placed 48 inches above the floor.

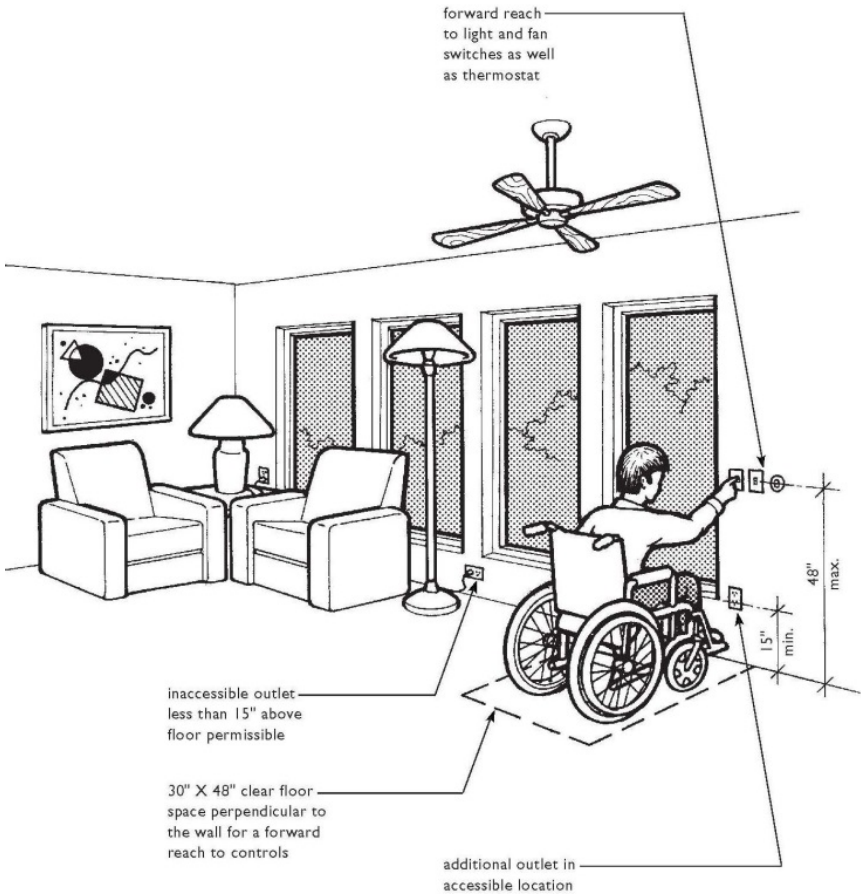

**All Covered Switches, Outlets, and Controls**

**Figure courtesy of HUD Fair Housing ACT Design Manual**

## Worth Considering

- ❑ Electrical outlets placed 18-24 inches above the floor to minimize bending.
- ❑ Telephone jacks at 18-24 inches above the floor.
- ❑ Water heater, electrical panel, furnace controls, natural gas and main water shut-off easily accessible with the operating instructions nearby.
- ❑ Switches that light up in the dark.
- ❑ Motion-activated lighting that turns on when someone enters the room.
- ❑ Rough-in wiring for audible and/or visual alarms for doorbell, security system and computer.
- ❑ Lighted doorbell installed 36-48 inches above the floor.
- ❑ Install a Westminster chime doorbell, which plays eight notes and gives the owner more information than a traditional two-note doorbell. It has frequencies from low to high and is great for folks with hearing loss.

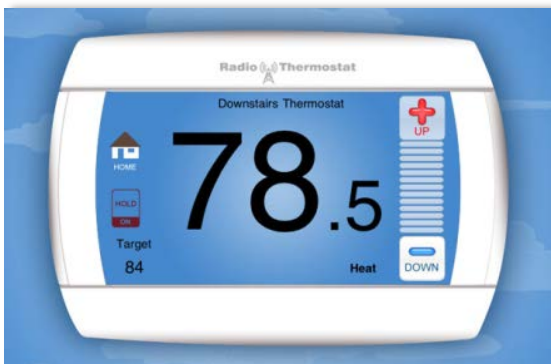



---

## Garage and Carports

Here in the Northwest, garages and carports are highly valued for the weather protection they provide. If you are building a new home or just looking to reorganize the space, here are a few suggestions:

### Essential

- Clear access to essential areas such as the main water shut-off, water heater and electrical panel.
- Garage door opener.
- A step-free entrance into the home.

### Worth Considering

- Garage door opener with battery backup.
- Keyless entry installed at the standard reachable height of 40-44 inches above finished floor and placed on the wall so there is clear floor space of 30-48 inches.
- Windows for natural lighting.
- Provide 114 inches of vertical clearance for large vans.

## Windows

Windows are incredibly important. The correct placement, type and size of window will reduce the need for artificial lighting and make a small space feel large.

### Essential

- Energy-efficient windows that require little strength to open, close and lock. The Arthritis Foundation ease-of-use product recommendation is good place to start.
- Installed at a height that allows people to see outdoors while seated and standing. Prefer 36-inch maximum sill height.
- Locks, latches and cranks installed at a maximum height of 44 inches above the floor.

### Worth Considering

- Screens that are lightweight and simple to remove and replace, ideally from the inside.
- Tilt-in windows that allow easy cleaning on both sides.

## Stairs and Elevators

### Essential

- Sturdy handrails on both sides of the stairway.
- Round handrails, use 1 ¼ - 1 ½-inches in diameter.
- Stair treads deep enough for the entire foot (11 inches) and maximum 7-inch-high risers. Many older homes were constructed under different standards and can be difficult for seniors.
- Well-lit with a light switch installed at the standard height at the top and bottom of the stairway.

### Worth Considering

- Stairway with no turns or curves and at least 4 feet wide to allow for a future chairlift.
- Add blocking before the drywall is installed to allow for a future chairlift.
- Anti-slip strips on the front edge of the steps in a color-contrasting material.
- No open risers.
- No carpeting on the stairs to reduce the risk of slipping.
- For new construction, stack two closets on top of one another. This creates an elevator shaft. Be sure the closets are a minimum of 8-feet by 8-feet.

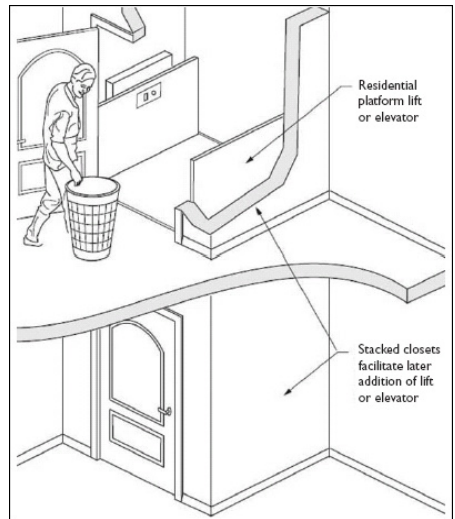

## Other things to consider

### Frailty, Disorientation and Dizziness

Many older people experience occasional dizziness, but a chronic condition resulting in disorientation, constant dizziness or frailty can cause familiar environments to become dangerous. If a family member displays any of these symptoms, make your home as safe as possible. Here are some helpful suggestions:

- ❑ Use furnishings that are stable and without sharp corners to minimize the effects of a fall.
- ❑ Remove scatter rugs, sharp objects and clutter, but keep the layout of the furniture and pathways the same.
- ❑ Consider placing barriers at dangerous locations to prevent unstable or disoriented people from falling.

### Lighting

Vision changes occur gradually as people age. Typically, older eyes require almost three times as much light as younger eyes. Installing focused task lighting helps.

### Range of Reach

A person in a chair or wheelchair is limited to a maximum side reach of 54 inches and a maximum frontal reach of 48 inches.

- ❑ The lowest easy reach from a seated position is approximately 9 inches to the side or 12 inches to the front.
- ❑ A standing person has a very different range of reach.

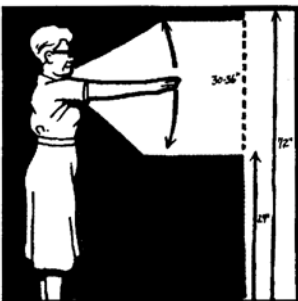

**Clark County  
Commission on Aging  
1300 Franklin Street  
Vancouver, WA 98660  
360-397-2280**

For more information on UGD and access to more resources, please visit the Commission on Aging's website at [www.clark.wa.gov/aging](http://www.clark.wa.gov/aging) or contact one of the committee members below:

<b>Chuck Frayer</b>	<b>frayerc@comcast.net</b>
<b>Jim Wilson</b>	<b>wilsonarchserv@comcast.net</b>
<b>Karin Woll</b>	<b>commonaging@gmail.com</b>
<b>Colete Anderson</b>	<b>colete.anderson@clark.wa.gov</b>

We would also like to thank the many volunteers who generously assisted with the development of this idea book.



For other formats, contact the Clark County ADA Office  
**Voice** (360) 397-2322, **Relay** 711 or (800) 833-6388,  
**Fax** (360) 397-6165, **E-mail** ADA@clark.wa.gov.